

A stylized map of the Asia-Pacific region is centered on the slide. The map is white and overlaid with a network of yellow lines and dots, representing a global or regional network. The background is a dark teal color with a subtle pattern of light teal geometric shapes and lines.

APAC Sales Meeting

Dec 2022

Vinmajor Enterprise Co, Ltd./Taiwan

Cheryl Tang

Project overview

Project	Electric garbage truck-Government project	Start	2018
Customer	NEW TSAIFA-Electric garbage truck FORMOSA POWER-Lithium Iron battery	Value	Until now-80,000 EUR Potential value-1,561,440 EUR
Project Phase	<ul style="list-style-type: none"> It's currently being used in electric garbage trucks. 		
Customer Goals	<ul style="list-style-type: none"> In line with government's energy saving and carbon reduction policy, the battery and electric garbage truck in this project can achieve all-electric compression, battery power and conventional power performance, low noise and low failure rate. This project is expected to last for more than ten years, estimated quantity of 200 units per year. 		
Project Description	<ul style="list-style-type: none"> 2018 - project design Q4,2019 - 10 units delivered for testing. 2020 - 190 units delivered to customer. Q4,2021 - delivered 50 units, budget cuts by government because of COVID. Q4,2022 - new order of 50 units, budget cuts by government because of COVID. <p>Plan:</p> <ul style="list-style-type: none"> By 2040 all garbage trucks will be replaced with the electric ones, to achieve energy saving and carbon reduction; estimated number of units for government garbage trucks - 5,000 units, for private garbage trucks - 1,000 units. 		



At a glance



Customer Problem

- Implementation of the Green Energy Policy given by the Government
- Specifications and Functional discussion
- Technical Support
- Budget coordination
- Penalty issue due to a delayed shipment

Solution

- The first stage - assisted circuit diagram design
- The second stage - assisted testing the device
- Mass production - Abnormal conditions occurred, assisted in identifying problems and verifying product effectiveness

Benefit for the Customer

Collaborated with Formosa Power to discuss product specifications and to provide complete technical service accordingly with NEW TSAIFA truck manufacturing

Project Scope

Until now-80,000EUR
Potential value-1,561,440 EUR



Win the project

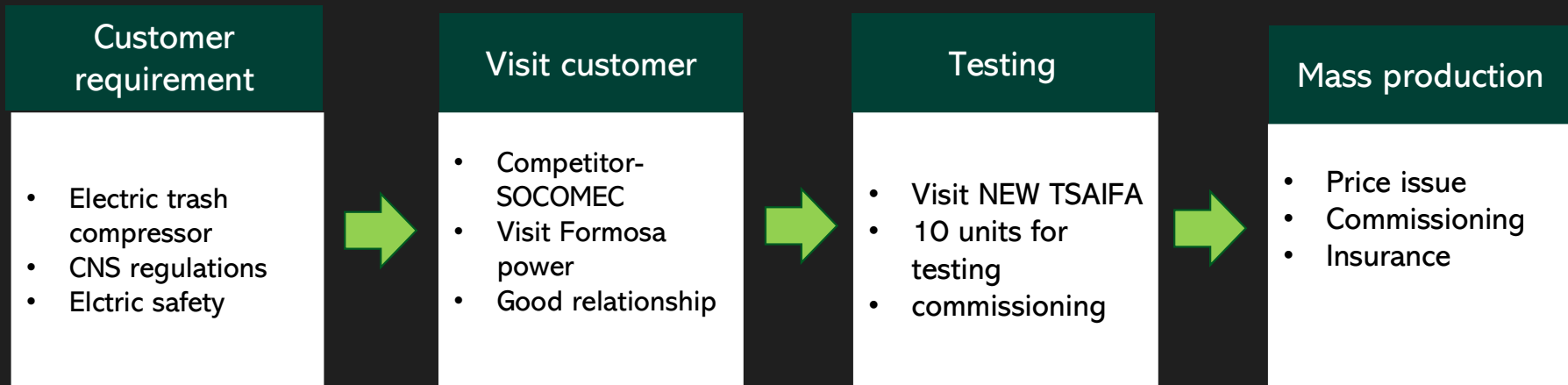

Electric garbage truck system

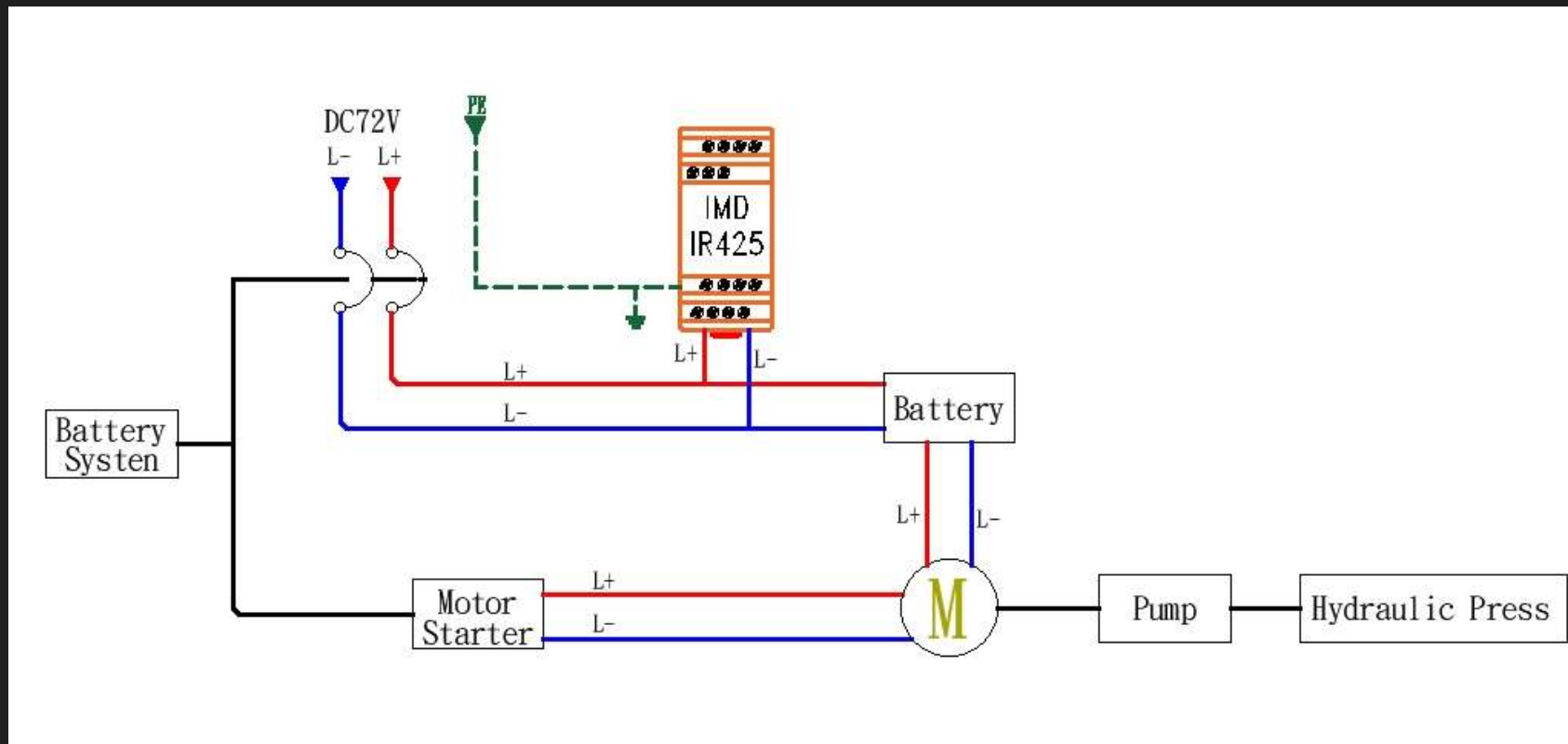

Electric garbage truck video



Electric garbage truck

