

Product overview

Power Quality and Energy Measurement

Electronic measuring and monitoring relays





Universal measuring devices and measuring relays to monitor electrical installations

Safety of power supply

To ensure personnel and equipment safety, operating conditions of electrical installations have to be monitored continuously. The physical quantities of current and voltage are not visible to humans without the use of appropriate measuring devices.

PEM series universal measuring devices (Power Quality and Energy Measurement) record all relevant parameters such as current, voltage, frequency, power, harmonics and the energy consumption of electrical supply systems, to mention but a few.

LINETRAXX® monitoring relays cover a broad spectrum; from single-channel current relays (CME420), loop monitoring (GM420) up to three-phase voltage relays (VMD460-NA) for power generation systems in accordance with VDE-AR-N 4105. Bender also offers special solutions for specific applications such as fully analogue devices (VMD258).

Highest level of availability despite system reactions

Increasing requirements regarding the high availability of electrical installations, and more and more complex production and automation processes conflict with an increased use of power electronics. System reactions become a topic of increasing concern to both operators and suppliers. Therefore digital universal measuring devices do more than record r.m.s. current and voltage values, they also replace analogue indicating instruments in switchboard and distributor cabinet doors. Harmonics, flicker severity, neutral currents and many more measuring quantities are recorded, evaluated and transferred via communication interfaces. Exceeded of configurable threshold values can also be signalled via relay outputs. The control centre of **Bender Monitoring Systems** centrally provides all relevant electrical installation data, which are easily accessible by means of a browser.

Power Quality and Energy Measurement PEM

In practice

- Universal measuring devices and measuring relays to monitor electrical installations..... 3
- Transparency for electrical installations 4
- Example for system set-up..... 5

Products

- Universal measuring devices 6
- Energy meter 8
- Measuring current transformers..... 8
- Condition Monitor 9

Measuring and monitoring relays

In practice

- Voltage and phase monitoring 10
- Current monitoring 11
- Special monitoring tasks 11

Products

- Voltage and frequency monitoring relays for AC and DC systems VME 12
- Voltage and frequency monitoring relays for 3(N)AC systems VMD 14
- Voltage and frequency monitoring relays for mains decoupling of power generation systems VMD 16
- Multifunctional voltage relay for DC, 1AC, 3(N)AC systems VMD 18
- Voltage relay for 3AC systems VMD 19
- Current relay for AC currents CME 20
- Current relay for 3AC currents CMD 21
- Current relay for AC currents CMS 22
- Monitoring relays for special applications 23

- Retrofit 24
- POWERSCOUT®
Find out today what won't happen tomorrow 25
- Support during all stages 26
- Bender. So that your world is safer 27

Power Quality and Energy Measurement

Transparency for electrical installations

Electrical supply systems are becoming larger over time. It is not rare that failures and disturbances are the consequence of overloaded systems. By means of a monitoring system comprising universal PEM series measuring devices of the potential impacts on protective measures, risks due to overloads or changes in energy consumption can be readily assessed before the next expansion stage.

Design of the monitoring system

A granular design of the monitoring system allows:

- Energy data acquisition by cost centres
- Faster fault localisation in the event of a fault
- An economic pyramid structure

The goal of a monitoring system must be to recognise even small changes in relevant measuring quantities such as leakage current or the harmonic content and to generate a prewarning in the event of deviations at the earliest possible stage.

A single measuring point in an electrical installation is not sufficient to generate curves of relevant measuring quantities that adequately represent voltage quality or leakage currents. Several measuring points need to be installed and adapted to correspond to the structure of the system.

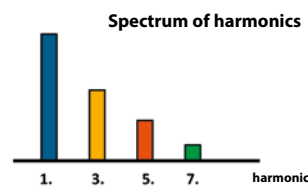
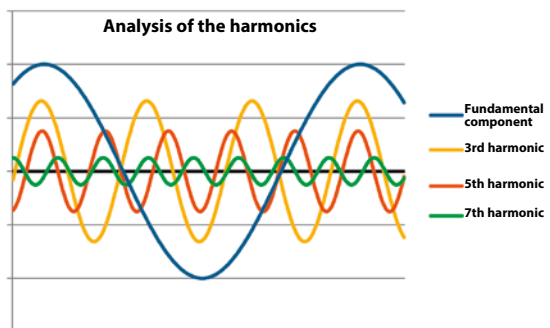
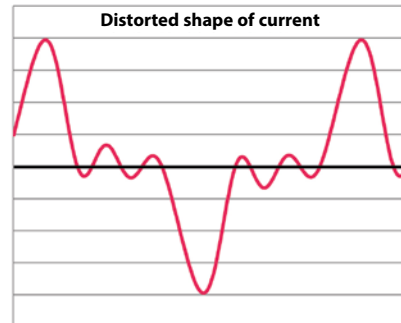

Example for system set-up

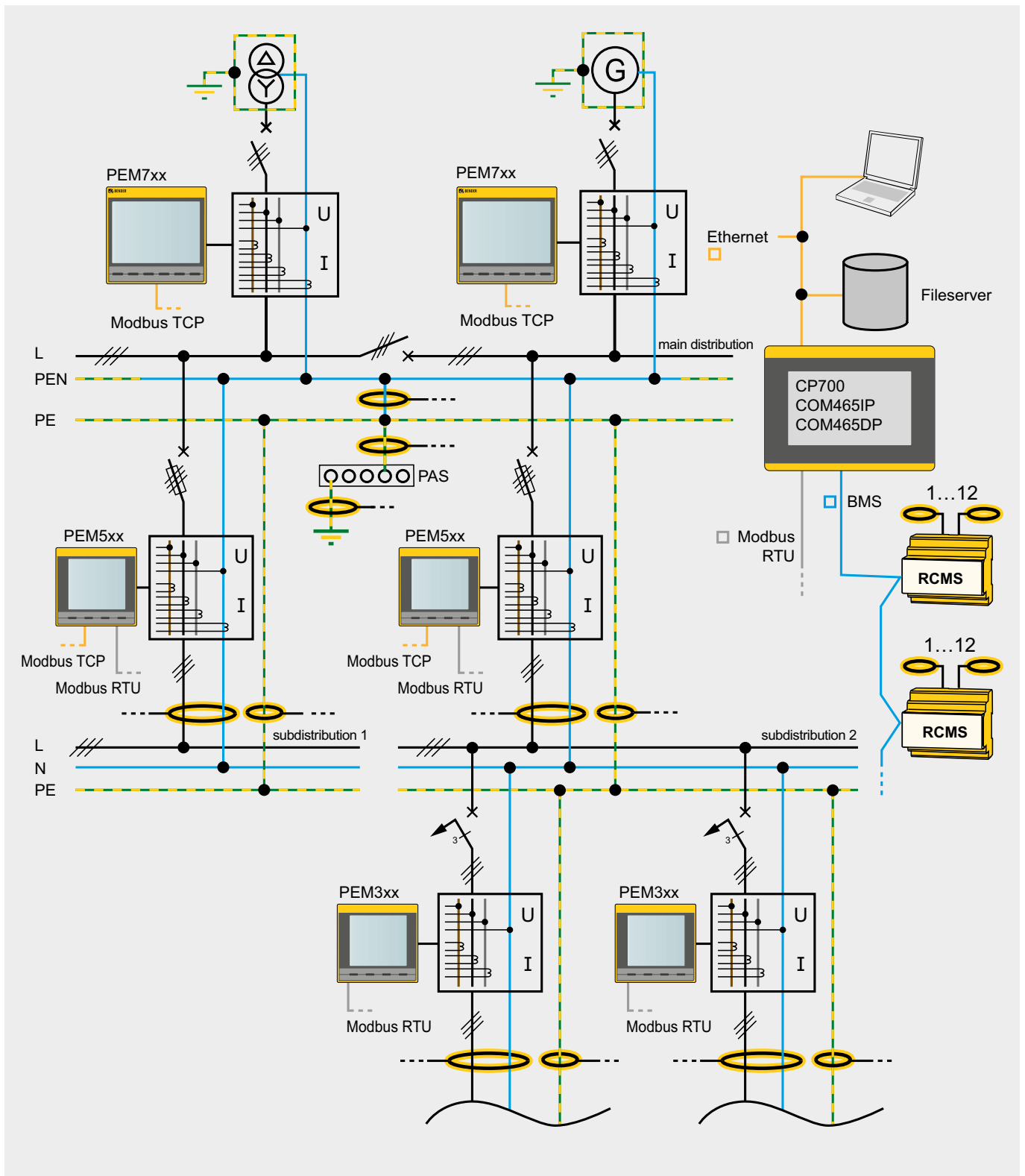

Universal measuring devices

Power Quality and Energy Measurement PEM



Normative requirements	Accuracy class of the active energy acc. to IEC 62053-22	0.5 S	0.2 S	0.2 S
	DIN EN 50160 (report)	–	–	■
DIN EN 61000-4-7 (harmonic)	Class II	Class I	Class I	
DIN EN 61000-4-15 (flicker) DIN EN 61000-4-30 (PQ measurement method)	–	–	■	
Measured quantities	Phase conductor voltages/line conductor voltages	■	■	■
	Phase currents	■	■	■
	Neutral current I_4	■ (PEM353-N only)	■	■
	Neutral current I_4 (calculated)	■	■	■
	Frequency/phase angle	■	■	■
	Reactive and active power import/ Reactive and active power export	■	■	■
	Voltage unbalance/current unbalance	■	■	■
	Power	per phase and total S in kVA, P in kW, Q in kvar		
	Displacement factor $\cos(\varphi)$ / power factor λ	■	■	■
	Total harmonic distortion (THD _U /THD _I)	up to the 31 st	up to the 63 rd	up to the 63 rd
	Harmonic components voltage	up to the 31 st	up to the 63 rd	up to the 63 rd
	Harmonic components current	up to the 31 st	up to the 63 rd	up to the 63 rd
	Transient detection	–	longer than 80 μ s	longer than 40 μ s
	Overvoltage (swell)	–	■	■
	Undervoltage (sag)	–	■	■
	Flicker severity P_{ST}	–	–	■
	Features	Data recorder / HighSpeed data recorder	5/0 (PEM353-N only)	16/4
Waveform recorder		–	32	128
Digital inputs		4	6	8
Digital outputs		2x pulse and/or solid-state (PEM353-P only)	–	2
Relay outputs (RO)		2 (PEM353, PEM353-N only)	3	4
technische Aspekte	Versorgungsspannung	AC/DC 95...250 V (47...440 Hz)		
	Abtastrate	3,2 kHz	12,8 kHz	25,6 kHz
	Temperatur	-25...+55 °C		
	Kommunikation	Modbus RTU, BACnet MS/TP, DNP	Modbus RTU & TCP	Modbus RTU & TCP

Ordering information

Digital inputs/outputs	Nominal system voltage	Interface		Current input	Type	Art. No.
		RS-485	Ethernet			
4/2	3(N) AC 230/400 V 3(N) AC 400/690 V ¹⁾	■	–	5 A ²⁾	PEM353	B93100355
					PEM353-P	B93100354
					PEM353-N	B93100353
6/3	3(N) AC 230/400 V	■	■	5 A	PEM575	B93100575
				1 A	PEM575-251	B93100576
	3(N) AC 69/120 V	■	■	5 A	PEM575-155	B93100579
				1 A	PEM575-151	B93100580
8/3	3(N) AC 100...690 V	■	■	1/5 A	PEM735	B93100735

¹⁾ TN and TT systems

²⁾ Note: In principle, measuring current transformers can also be operated with 1 A secondary current on measuring devices with 5 A current input. In this case, the accuracy class is expected to be reduced by one class (e.g. 0.5 to 1).

Energy meters and measuring current transformers

Energy meter

Along with numerous measuring values, all PEM series devices can measure energy and power values. If, however, a measuring point is used for billing purposes, special requirements must be met (subject to obligatory calibration). Energy meters with the Measurement Instrument Directive (MID) conformity mark meet these requirements.



Ordering information

Description	Type	Art. No.
Energy meter 1Ph/32 A MID Modbus RTU	ALD1	B93101005
Energy meter 3Ph/65 A MID Modbus RTU	ALE3	B93101006
Energy meter 3Ph/6 A MID Modbus RTU	AWD3	B93101007
SO pulse counter (four-fold) with Modbus RTU	PCD7	B93101008
Sealable cover for ALD1 (two per counter)	-	B93101009
Sealable cover for ALE3/AWD3 (four per counter)	-	B93101010

Measuring current transformers

All PEM series measuring devices can be operated with standard measuring current transformers (1 A or 5 A). To comply with the accuracy class (e.g. 0.5 S), the measuring device and the measuring current transformers used must comply with class 0.5 S or better.

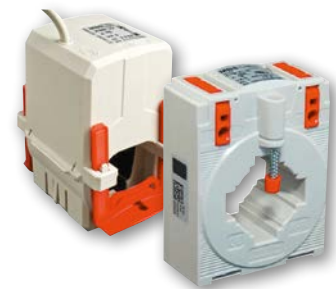

Ordering information

Primary current	Accuracy	Secondary current	Type	Design	Art. No.
60	1	5	WL605 KL.1	CTB41	B98086001
		1	WL60-1 KL.1	CTB41	B98086002
75	1	5	WL755 KL.1	CTB41	B98086003
		1	WL75-1 KL.1	CTB41	B98086004
125	0.5	5	WL1255 KL.0,5	CTB41	B98086005
		1	WL125-1 KL.0,5	CTB41	B98086006
	1	5	WL125-5 KL.1	CTB41	B98086007
		1	WL125-1 KL.1	CTB41	B98086008
150	0.5	5	WL1505 KL.0,5	CTB41	B98086009
		1	WL150-1 KL.0,5	CTB41	B98086010
	1	5	WL150-5 KL.1	CTB41	B98086011
		1	WL150-1 KL.1	CTB41	B98086012
200	0.5	5	WL2005 KL.0,5	CTB41	B98086013
		1	WL200-1 KL.0,5	CTB41	B98086014
	1	5	WL200-5 KL.1	CTB41	B98086015
		1	WL200-1 KL.1	CTB41	B98086016
250	0.5	5	WL2505 KL.0,5	CTB41	B98086017
		1	WL250-1 KL.0,5	CTB41	B98086018
	1	5	WL250-5 KL.1	CTB41	B98086019
		1	WL250-1 KL.1	CTB41	B98086020
300	0.5	5	WL3005 KL.0,5	CTB41	B98086021
		1	WL300-1 KL.0,5	CTB41	B98086022
	1	5	WL300-5 KL.1	CTB41	B98086023
		1	WL300-1 KL.1	CTB41	B98086024

Primary current	Accuracy	Secondary current	Type	Design	Art. No.
400	0.5	1	WL400-1 KL.0,5	CTB41	B98086025
	1	5	WL400-5 KL.1	CTB41	B98086026
	0.5	5	WL400-5 KL.0,5	CTB41	B98086027
	1	1	WL400-1 KL.1	CTB41	B98086028
500	1	5	WL500-5 KL.1	CTB41	B98086029
	0.5	5	WL500-5 KL.0,5	CTB41	B98086031
	1	1	WL500-1 KL.1	CTB41	B98086032
	0.5	1	WL500-1 KL.0,5	CTB41	B98086033
	1	5	WL600-5 KL.1	CTB51	B98086034
600	0.5	5	WL600-5 KL.0,5	CTB51	B98086035
	1	1	WL600-1 KL.1	CTB51	B98086036
	0.5	1	WL600-1 KL.0,5	CTB51	B98086037
	1	5	WL800-5 KL.1	CTB51	B98086038
800	0.5	5	WL800-5 KL.0,5	CTB51	B98086039
	1	1	WL800-1 KL.1	CTB51	B98086040
	0.5	1	WL800-1 KL.0,5	CTB51	B98086041
1000	1	5	WL1000-5 KL.1	CTB51	B98086042
	0.5	5	WL1000-5 KL.0,5	CTB51	B98086043
	1	1	WL1000-1 KL.1	CTB51	B98086044
	0.5	1	WL1000-1 KL.0,5	CTB51	B98086045
50	3F55	1	WLS501 KL3F55	KBR18	B98086046
100	3F55	1	WLS1001 KL.3F55	KBR18	B98086047
150	3F55	1	WLS1501 KL.3F55	KBR18	B98086048
250	3F55	1	WLS2501 KL.3F55	KBR32	B98086049
500	3F55	1	WLS5001 KL.1F55	KBR32	B98086050

Condition Monitor for Bender BMS and universal measuring devices



Several measured values per second are generated by a monitoring system. This information is collected automatically, evaluated according to the system and processed specifically for each user groups.

Application		Condition Monitoring/Gateway
Functions	Protocol input	BMS/Modbus RTU/TCP
	Protocol output	Ethernet/Modbus/TCP
	Indication	7" colour LCD
	Alarm messages	■ 1, 2, 3)
	Measured values	■ 1, 2, 3)
	Device parameterisation	■ 1)
	Alarm list	■ 1, 3)
	History memory	■ 1)
	Diagrams	■ 1, 3)
	Visualisation	■ 1)
	E-mail notification	■ 1)
	Device tests	■ 1, 2)
	Data logger	■ 1)
Connection	BMS	pluggable screw terminals
	Output	RJ 45
System requirements	Supply voltage U_s	DC 24 V
	Browser	Internet Explorer, Opera, Firefox etc. with Silverlight plugin

Webserver

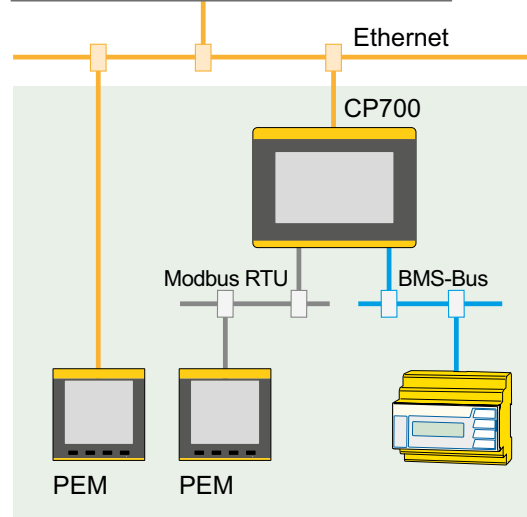
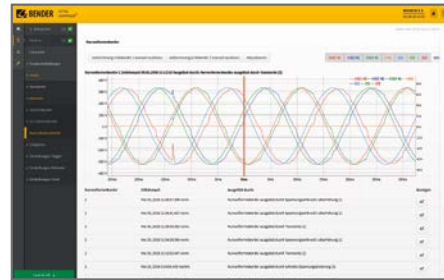

- 1) Available functions on the web server – Accessible by means of a PC using a browser
- 2) Available via protocol
- 3) On the device's own LC display

Ordering information

Supply voltage/ frequency range U_s	Power consumption	Type	Art. No.
DC 24V/± 25 %	typ. 11 W/max. 26 W	CP700	B95061030









Measuring and monitoring relays

Voltage and phase monitoring

Multifunctional voltage and frequency monitoring relays are available for monitoring various parameters in main and auxiliary circuits. They provide essential information well in advance so

that faults and disturbances are detected at an early stage and take appropriate action before time and cost intensive operational interruptions and damage to property occur.

Device overview voltage monitoring

									
	VME420 Page 12	VME421H Page 12	VMD420 Page 14	VMD421H Page 14	VMD423 Page 16	VMD423H Page 16	VMD460-NA Page 16	VMD461 Page 18	VMD258 Page 19
DC	$U<, U>$	$U<, U>$							
AC	$U<, U>$	$U<, U>$					$U<, U<<, U>, U>>, U_{10min}>$	$U<, U<<, U<<<, U>, U>>, U>>>$	
3 AC			$U<, U>$	$U<, U>$			$U<, U<<, U>, U>>, U_{10min}>$	$U<, U<<, U<<<, U>, U>>, U>>>$	$U<, U>$
3/N AC			$U<, U>$	$U<, U>$	$U<, U>, U_{10min}>$	$U<, U>, U_{10min}>$	$U<, U<<, U>, U>>, U_{10min}>$	$U<, U<<, U<<<, U>, U>>, U>>>$	
Frequency	$f<, f>$	$f<, f>$	$f<, f>$	$f<, f>$	$f<, f>$	$f<, f>$	$f<, f<<, f>, f>>$	$f<, f<<, f<<<, f>, f>>, f>>>$	
Phase sequence			■	■	■	■	■	■	
Phase failure			■	■	■	■	■	■	
Asymmetry			■	■	■	■	■	■	
Versorgungsspannung U_s	external	system	external	system	external	system	external	external	system

Example applications of voltage and phase monitoring



Measured quantity	Common causes of faults	Possible effects
Undervoltage	Voltage variations Blown fuses Wire breakage	Failure or destruction of motors due to overheating Accidental reset of a device Undefined switching and system states Accidental restart
Overvoltage	Voltage variations	Damage to system components due to overvoltage Accidental switching on of a system
Phase sequence	Reversed conductors, faulty extension cords	Incorrect rotation direction of a motor, destruction of roller drives Hazardous situations to man and machine when using mobile devices and systems
Phase failure	Blowing of fuse(s)/control voltage failure Wire breakage	Overheating of motors due to single-phase operation
Phase unbalance	Unbalanced distribution of the load Phase failure with energy recovery	Overheating of motors due to unbalanced voltages Failure of system parts



Current monitoring

Current relays are mainly used to monitor the load current of motors and other electrical loads. They also provide essential information well in advance so that faults and disturbances are detected at an early stage and appropriate action is taken before time and cost intensive operational interruptions and damage to property occur.

Device overview: current monitoring

				
		CME420 Page 20	CMD420/CMD421 Page 21	CMS460 Page 22
AC	with U_s	$I_{<}, I_{>}$		$I_{<}, I_{>}$
3 AC	with U_s		$I_{<}, I_{>}$	$I_{<}, I_{>}$

Special monitoring tasks

Fault voltage relays are used as a protective measure for welding systems. The relays monitor the secondary windings of welding transformers in accordance with the requirements of DIN VDE 0545-1(VDE 0545-1):1990-01.

Loop monitoring relays monitor conductor loops for interruptions and short-circuits, for example, supply leads of mobile machines and devices.

Device overview: specific applications

			
	GM420 Page 23	CD440 Page 18	ES258 Page 19
Loop monitoring	<input type="checkbox"/>		
Coupling device		<input type="checkbox"/>	
Energy storage			<input type="checkbox"/>

Example applications

Measured quantity	Application
Current monitoring	Current consumption of motors, such as pumps, elevators, cranes
	Monitoring of lighting systems, heating circuits, charging stations
	Overload control of hoisting gear and means of transportation
	Monitoring of locking devices, driving to end stops
	Monitoring of emergency lighting
	Monitoring of navigation lighting on high-rise buildings
	Monitoring of screw conveyors, for example, in sewage plants, in case of blocking of conveyor systems
	Dust removal in wood working
	Monitoring of small currents, for example, low-power motors, indicator lamps

Voltage and frequency monitoring relays for AC and DC systems

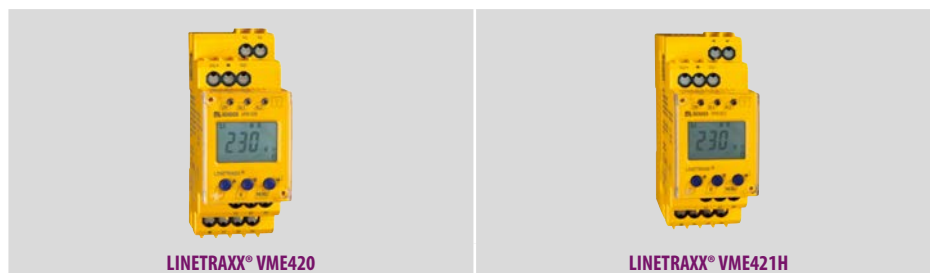

Mains voltage	AC	<input type="checkbox"/>	<input type="checkbox"/>
	DC	<input type="checkbox"/>	<input type="checkbox"/>
Function	Undervoltage/overvoltage $U_{<}, U_{>}$	<input type="checkbox"/>	<input type="checkbox"/>
	Underfrequency/overfrequency $f_{<}, f_{>}$	<input type="checkbox"/>	<input type="checkbox"/>
	Preset function	<input type="checkbox"/>	<input type="checkbox"/>
	Password protection	<input type="checkbox"/>	<input type="checkbox"/>
	History memory (first alarm value)	<input type="checkbox"/>	<input type="checkbox"/>
Supply voltage U_s		DC 9.6...94 V/AC 16...72 V, AC/DC 70...300 V	U_n
Integrated energy storage device		–	<input type="checkbox"/>
Response values	Undervoltage/Overvoltage $U_{<}, U_{>}$	AC/DC 6...300 V	AC/DC 70...300 V
	Hysteresis U	1...40 %	1...40 %
	Underfrequency/Overfrequency $f_{<}, f_{>}$	10...500 Hz	70...500 Hz
	Hysteresis f	0.1...2 Hz	0.1...2 Hz
	Rated frequency	DC, 15...460 Hz	DC, 15...460 Hz
	Operating time, voltage	DC/AC 16,7 Hz: ≤ 130 ms, AC 42...460 Hz: ≤ 70 ms	DC/AC 16,7 Hz: ≤ 130 ms, AC 42...460 Hz: ≤ 70 ms
	Operating time frequency	AC 15...460 Hz: ≤ 310 ms	AC 15...460 Hz: ≤ 310 ms
	Response delay t_{on}	0...300 s	0...300 s
	Delay on release t_{off}	0...300 s	0...300 s
	Start-up delay t	0...300 s	0...300 s
Alarm LEDs	Power On LED	<input type="checkbox"/>	<input type="checkbox"/>
	Alarm LEDs	<input type="checkbox"/>	<input type="checkbox"/>
Switching elements	Number of switching elements	2 x 1 changeover contacts, programmable	2 x 1 changeover contacts, programmable
	Operating principle	N/O operation or N/C operation, programmable	N/O operation or N/C operation, programmable
Enclosure dimensions in mm (H x W x D)		90 x 36 x 70.5	90 x 36 x 105.5
Accessories		Mounting clip	Mounting clip
Interface option		M	M
Standards, approvals and certifications		UL, Lloyd's Register	UL, Lloyd's Register



The voltage and frequency monitoring relays are designed to monitor the upper and lower limits of one or several defined response values. The devices are suitable for AC and DC systems.

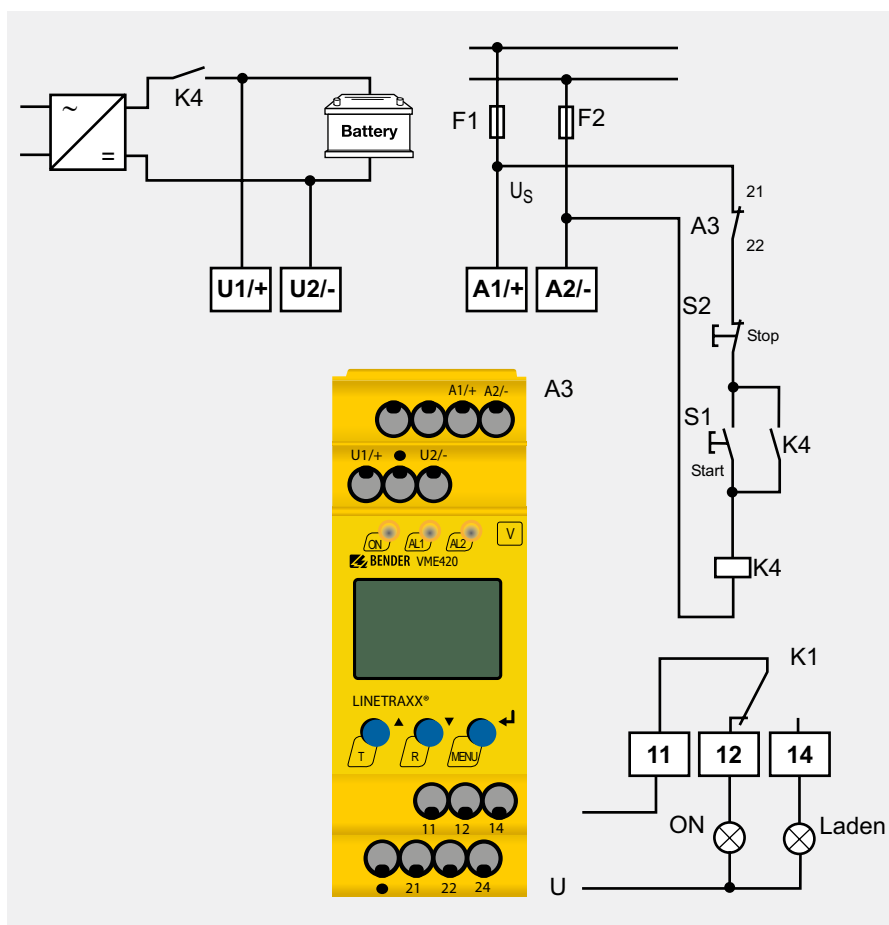

Ordering information

Nominal system voltage ¹⁾ U_n	Supply voltage ¹⁾ U_s	Type	Art. No.	
			Screw-type terminal	Push-wire terminal
AC 16...72V/DC 9.6...94V	AC 16...72V, 15...460 Hz/DC 9.6...94V	VME420-D-1	B93010001	B73010001
AC/DC 70...300V	AC 70...300V, 15...460 Hz/DC 70...300V	VME420-D-2	B93010002	B73010002
AC 9.6...150V, 15...460 Hz/DC 9.6...150V	U_n	VME421H-D-1	B93010003	B73010003
AC 70...300V, 15...460 Hz/DC 70...300V	U_n	VME421H-D-2	B93010004	B73010004

¹⁾ Absolute values

Accessories

Description	Art. No.
Mounting clip for screw mounting (1 piece per device)	B98060008

Voltage and frequency monitoring relays for 3(N)AC systems



LINETRAXX® VMD420



LINETRAXX® VMD421H

Mains voltage	3AC	<input type="checkbox"/>	<input type="checkbox"/>
	3NAC	<input type="checkbox"/>	<input type="checkbox"/>
Function	Undervoltage/overvoltage $U_{<, U_{>}$	<input type="checkbox"/>	<input type="checkbox"/>
	Underfrequency/Overfrequency $f_{<, f_{>}$	<input type="checkbox"/>	<input type="checkbox"/>
	Phase sequence	<input type="checkbox"/>	<input type="checkbox"/>
	Phase failure	<input type="checkbox"/>	<input type="checkbox"/>
	Asymmetry	<input type="checkbox"/>	<input type="checkbox"/>
	Preset function	<input type="checkbox"/>	<input type="checkbox"/>
	Password protection	<input type="checkbox"/>	<input type="checkbox"/>
	History memory (first alarm value)	<input type="checkbox"/>	<input type="checkbox"/>
	Supply voltage range U_s	DC 9.6...94V/AC 16...72V, AC/DC 70...300V	U_n
Integrated energy storage device	–	min. 2.5 s	
Response values	Undervoltage/Overvoltage $U_{<, U_{>}$	AC 6...500V/6...288V	AC 70...500 /70...288 V
	Hysteresis U	1...40 %	1...40 %
	Underfrequency/Overfrequency $f_{<, f_{>}$	10...500 Hz	10...500 Hz
	Hysteresis f	0.1...2 Hz	0.1...2 Hz
	Asymmetry	5...30 %	5...30 %
	Rated frequency	15...460 Hz	15...460 Hz
	Operating time voltage/frequency	≤ 140/335 ms	≤ 140/335 ms
	Response delay t_{on}	0...300 s	0...300 s
	Delay on release t_{off}	0...300 s	0...300 s
Start-up delay t	0...300 s	0...300 s	
Alarm LEDs	Power On LED	<input type="checkbox"/>	<input type="checkbox"/>
	Alarm LEDs	<input type="checkbox"/>	<input type="checkbox"/>
Switches/buttons	Undervoltage/overvoltage	–	–
	AC/DC switches	–	–
	Buttons	TEST/RESET/MENU	TEST/RESET/MENU
Switching elements	Number of switching elements	2 x 1 changeover contacts, programmable	2 x 1 changeover contacts, programmable
	Operating principle	N/O or N/C operation, programmable	N/O or N/C operation, programmable
Enclosure dimensions in mm (H x W x D)		90 x 36 x 70.5	90 x 36 x 105.5
Accessories		Mounting clip	Mounting clip
Interface option		M	M
Standards, approvals and certifications		UL, Lloyd's Register	UL, Lloyd's Register

The VMD420/421H series voltage and frequency monitoring relays are designed to monitor the upper and lower limits of one or several defined response values. The devices can be used for three-phase systems with or without an N conductor. Furthermore, the devices feature additional monitoring functions such as phase sequence, phase failure, frequency, and Asymmetry monitoring.

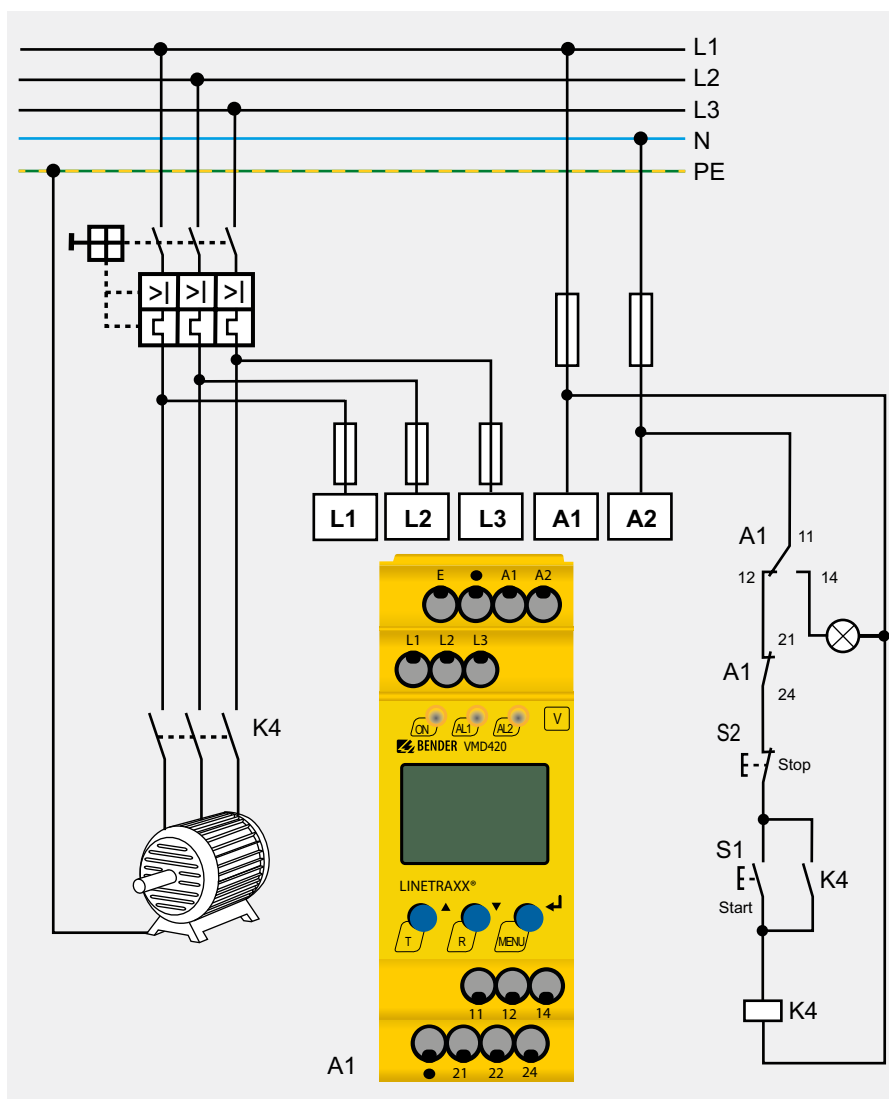

Ordering information

Nominal system voltage ¹⁾ U_n	Supply voltage ¹⁾ U_s	Type	Art. No.	
			Screw-type terminal	Push-wire terminal
3(N)AC 0...500/288 V	AC 16...72 V/DC 9.6...94 V, 15...460 Hz	VMD420-D-1	B93010005	B73010005
	AC/DC 70...300 V, 15...460 Hz	VMD420-D-2	B93010006	B73010006
3(N)AC 70...500 V, 15...460 Hz	U_n	VMD421H-D-3	B93010007	B73010007

¹⁾ Absolute values

Accessories

Description	Art. No.
Mounting clip for screw mounting (1 piece per device)	B98060008

Voltage and frequency monitoring relays for mains decoupling of power generation systems



Mains voltage	3AC	<input type="checkbox"/>	<input type="checkbox"/>	<input type="checkbox"/>
	3NAC	<input type="checkbox"/>	<input type="checkbox"/>	<input type="checkbox"/>
Function	Undervoltage/Overvoltage $U<, U>, U>10\text{min}$	<input type="checkbox"/>	<input type="checkbox"/>	<input type="checkbox"/>
	Undervoltage/Overvoltage $U<<, U>>$	-	-	<input type="checkbox"/>
	Underfrequency/Overfrequency $f<, f>$	<input type="checkbox"/>	<input type="checkbox"/>	<input type="checkbox"/>
	Underfrequency/Overfrequency $f<<, f>>$	-	-	<input type="checkbox"/>
	Phase sequence	<input type="checkbox"/>	<input type="checkbox"/>	<input type="checkbox"/>
	Phase failure	<input type="checkbox"/>	<input type="checkbox"/>	<input type="checkbox"/>
	Asymmetry	<input type="checkbox"/>	<input type="checkbox"/>	<input type="checkbox"/>
	ROCOF df/dt	-	-	<input type="checkbox"/>
	Vector surge	-	-	<input type="checkbox"/>
	Password protection	<input type="checkbox"/>	<input type="checkbox"/>	<input type="checkbox"/>
	History memory	<input type="checkbox"/>	<input type="checkbox"/>	<input type="checkbox"/>
Supply voltage U_s		DC 9.6...94 V/AC 16...72 V, AC/DC 70...300 V	U_n	AC/DC 100...240 V
Integrated energy storage device		-	min. 2.5 s	-
Rated frequency		40...65 Hz	40...65 Hz	45...65 Hz
Indication	Power On LED	<input type="checkbox"/>	<input type="checkbox"/>	<input type="checkbox"/>
	Alarm LED undervoltage	<input type="checkbox"/>	<input type="checkbox"/>	<input type="checkbox"/>
	Alarm LED overvoltage	<input type="checkbox"/>	<input type="checkbox"/>	<input type="checkbox"/>
Switching elements	Number of switching elements	2 x 1 changeover contacts, programmable	2 x 1 changeover contacts, programmable	2 x 1 changeover contact
	Operating principle	N/O or N/C operation, programmable	N/O or N/C operation, programmable	N/O or N/C operation, programmable
Enclosure dimensions in mm (H x W x D)		90 x 36 x 70.5	90 x 36 x 105.5	90 x 108 x 74
Accessories		Mounting rail	Mounting rail	Mounting rail
Standards, approvals and certifications		UL508	UL508	UL 508, VDE-AR-N 4105:2018-11, VDE-AR-N 4105:2011-08, VDE-AR-N 4110:2018-11, BDEW technical guideline 2008 incl. amendments until 01.2013 G99/1:2019, G59/2, G59/3, G98/1:2019, G83/2, CEI 0-21 (:2012-06, :V1:2012-12, :V2:2013-12, :2014-09, :V1:2014-12, :2016-07, V1:2017-07), C10/11:2012-06, DIN V VDE V 0126-1-1 (:2016-06, / A1:2012-02)

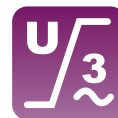

Typical applications VMD423(H)

- Monitoring of automatic switching points between private electricity generation power system in parallel operation with the public low voltage grid
- Applications according to DIN V VDE V 0126-1-1 (VDEV 0126-1-1): 2006-02, C 10/11, EN 50438:2007
- Universally applicable for photovoltaic systems, CHPs (Combined Heat and Power plants), wind power and hydro power plants

Typical applications VMD460-NA

- Central NS protection (VDE-AR-N 4105)
- Protective disconnection (VDE-AR-N 4110, BDEW)
- Interface Protection (IP) (Engineering Recommendations; EREC G99, G59, G83, G59)
- Protezione di interfaccia (CEI 0-21)
- Automatic disconnection device between a generating plant parallel to the network and the public network
- Universal for generating plants for safe network decoupling

Ordering information

Supply voltage ¹⁾ U_S	Response value	Type	Art. No.	
			Screw-type terminal	Push-wire terminal
AC 16...72 V, 15...460 Hz/DC 9.6...94 V	AC 10...500 V	VMD423-D-1	B93010020	B73010020
AC 70...300 V, 15...460 Hz/DC 70...300 V	AC 10...500 V	VMD423-D-2	B93010021	B73010021
U_n	AC 70...500 V	VMD423H-D-3	B93010022	B73010022
AC/DC 100...240 V	AC 400/230 V	VMD460-NA-D-2	B93010045	–

¹⁾ Absolute values

Accessories

Description	Art. No.
Mounting clip for screw mounting (1 piece per device)	B98060008

Multifunctional voltage relay for DC, 1AC, 3(N)AC systems

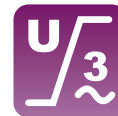

The multifunctional voltage monitoring relay VMD461 monitors frequencies, undervoltages and overvoltages in DC, AC and 3(N)AC systems. The phase voltages and/or line-to-line voltages are measured as r.m.s. value and are continuously shown on the device display. The measured value required to trigger the alarm relay is stored.

Ordering information

Supply voltage U_s	Type	Art. No.
AC/DC 100...240 V	VMD461-D-2	B93010047

Accessories

Description	Art. No.
Mounting clip for screw mounting (1 piece per device)	B98060008
Coupling device CD440	B73010046

Mains voltage	3AC	<input type="checkbox"/>
	3NAC	<input type="checkbox"/>
Function	Undervoltage/Overvoltage $U<, U>, U<<, U>>, U<<<, U>>>$	<input type="checkbox"/>
	Underfrequency/Overfrequency $f<, f>, f<<, f>>, f<<<, f>>>$	<input type="checkbox"/>
	Phase sequence	<input type="checkbox"/>
	Phase failure	<input type="checkbox"/>
	Asymmetry	<input type="checkbox"/>
	ROCOF df/dt	<input type="checkbox"/>
	Vector surge	<input type="checkbox"/>
	Password protection	<input type="checkbox"/>
	History memory	<input type="checkbox"/>
Supply voltage U_s		AC/DC 100...240 V
Indication	Power On LED	<input type="checkbox"/>
	Alarm LED undervoltage	<input type="checkbox"/>
	Alarm LED overvoltage	<input type="checkbox"/>
Switching elements	Number of switching elements	2 x 1 changeover contact
	Operating principle	N/O or N/C operation
Enclosure dimensions in mm (H x W x D)		90 x 108 x 74
Accessories		CD440
Standards, approvals and certifications		UL508



Monitored voltage range	DC/3AC 1200; 1AC/3NAC 690 V
Enclosure dimensions in mm (H x W x D)	93 x 71,7 x 62,5

Voltage relay for 3AC systems



Voltage relays monitor the upper and lower limits of preset response values in 3AC systems up to 690 V. The VMD258 is a purely analogue device with no microcontroller and software and is highly accurate for plant protection.

Ordering information

Mains voltage 3AC		■
Function	Undervoltage/overvoltage $U<, U>$	■
Supply voltage U_S		U_n
Energy storage		external energy storage device ES258
Measuring circuit	Measuring range/nominal system voltage U_n	3AC 690/500/480/440/400/230/110/100 V
	Rated frequency	45...66 Hz
	Response values	adjustable $U>, U<$
	Hysteresis	< 3 %
	Response time Undervoltage/overvoltage	100 ms/60ms
	Response delay	0...5 s ± 10 %
	Delay on release	100 ms ± 20 %
Alarm LEDs	Power On LED	■
	Alarm LED undervoltage	■
	Alarm LED overvoltage	■
Potentiometer	Undervoltage	■
	Overvoltage	■
	Response value	■
Switching elements	Number of switching elements	2 x 2 changeover contact
	Operating principle	N/C operation (undervoltage) N/O operation (overvoltage)
Enclosure dimensions in mm (H x W x D)		93 x 107.5 x 110.1
Accessories		ES258

Connection	Type	Art. No.
3AC 100 V	VMD258 3AC 100 V	B93010060
3AC 110 V	VMD258 3AC 110 V	B93010061
3AC 230 V	VMD258 3AC 230 V	B93010062
3AC 400 V	VMD258 3AC 400 V	B93010063
3AC 440 V	VMD258 3AC 440 V	B93010064
3AC 480 V	VMD258 3AC 480 V	B93010065
3AC 500 V	VMD258 3AC 500 V	B93010066
3AC 690 V	VMD258 3AC 690 V	B93010067

Accessories

Description	Art.No.
Additional mounting clips (screwmounting)	B98060008
External storage ES258	B93010068



Supply voltage U_S	DC 41...47 V
Enclosure dimensions in mm (H x W x D)	85 x 52.5 x 70

Current relay for AC currents



Current relays are designed to monitor the upper and lower limits of one or several defined response values.

Mains voltage AC		■
Function	Undercurrent/overcurrent $I<, I>$	■
	Window discriminator function	■
	Password protection	■
	History memory (first alarm value)	■
Supply voltage U_s		DC 9.6...94 V/AC 16...72 V, AC/DC 70...300 V
Response values	Current	AC 0.05...16 A true r.m.s.
	Rated frequency	42...2000 Hz
	Setting range	0.1...16 A x transformation ratio n
	Transformation ratio n	1...2000
	Hysteresis	10...40 %
	Response time	≤ 70 ms
	Response delay	0...99 s
	Delay on release	0...99 s
Alarm LEDs	Operation	■
	Alarm undercurrent	■
	Alarm overcurrent	■
Switching elements	Number of switching elements	2 x 1 changeover contacts, programmable
	Operating principle	N/O or N/C operation, programmable
Enclosure	Enclosure dimensions in mm (H x W x D)	90 x 36 x 70.5
	Accessories	Mounting clip
	Interface option	M
	Standards, approvals and certifications	UL508

Ordering information

Setting range	Supply voltage $U_s^{1)}$	Type	Art. No.	
			Screw-type terminal	Push-wire terminal
AC 0.1...16 A	AC 16...72 V, 42...460 Hz/ DC 9.6...94 V	CME420-D-1	B93060001	B73060001
AC 0.1...16 A	AC 70...300 V, 42...460 Hz/ DC 70...300 V	CME420-D-2	B93060002	B73060002

¹⁾ Absolute values

Accessories

Description	Art. No.
Mounting clip for XM420 enclosure	B98060008

Current relay for 3AC currents



LINETRAXX® CMD420/CMD421

AC current relays are designed to monitor the upper and lower limit of a defined response value.

Ordering information

Mains voltage 3AC		■
Function	Undercurrent/overcurrent $I_{<}, I_{>}$	■
	Window discriminator function	■
Supply voltage U_S		DC 9.6...94 V/AC 16...72 V, AC/DC 70...300 V
Response values	Current	AC 0.05...16 A True r.m.s.
	Rated frequency	42...2000 Hz
	Setting range	0.1...16 A x transformation ratio n
	Hysteresis approx.	1...40 %
	Response time approx.	≤ 130 ms
	Response delay	0...300 s
	Delay on release	0...300 s
Alarm LEDs	Operation	■
	Alarm undercurrent	■
	Alarm overcurrent	■
	Alarm, window discriminator function	■
Switching elements	Number of switching elements	2 x 1 changeover contacts, programmable
	Operating principle	N/O or N/C operation
Enclosure	Enclosure dimensions in mm (H x W x D)	90 x 36 x 70.5
	Accessories	Mounting clip

Supply voltage U_S ¹⁾	Type	Art. No.	
		Screw-type terminal	Push-wire terminal
AC 16...72 V/DC 9.6 V...94 V, 15...460 Hz	CMD420-D-1	B93060006	B73060006
AC/DC 70...300 V, 15...460 Hz	CMD420-D-2	B93060007	B73060007
AC 16...72 V/DC 9.6 V...94 V, 15...460 Hz	CMD421-D-1	B93060008	B73060008
AC/DC 70...300 V, 15...460 Hz	CMD421-D-2	B93060009	B73060009

¹⁾ Absolute values

Accessories

Description	Art. No.
Mounting clip for XM420 enclosure	B98060008

Current relay for AC currents



12 channel AC current relays monitor the upper and lower limits of a defined values.

Ordering information

Supply voltage U_s ¹⁾	Type	Art. No.
AC 16...72 V, 42...460 Hz/DC 16...94 V	CMS460-D-1	B94053017
AC 70...276 V, 42...460 Hz/DC 70...276 V	CMS460-D-2	B94053018

¹⁾ Absolute values

Mains voltage AC		■
Function	Undercurrent/overcurrent $I<, I>$	■
Supply voltage U_s		DC 16...94 V/AC 16...72 V, 42...460 Hz DC 70...276 V/AC 70...276 V, 42...460 Hz
Measuring circuit	Measuring channels per device	12
	Rated frequency	42...2000 Hz
	Hysteresis approx.	2...40 %
	Response time	≤ 180 ms
	Response delay	0...999 s
Indication/ alarm LEDs	Delay on release	0...999 s
	LC display	■
	Operation	■
	Alarm undercurrent	■
Switching elements	Alarm overcurrent	■
	Number of switching elements	2 x 1 changeover contact
	Operating principle	N/O or N/C operation
Enclosure	Enclosure dimensions in mm (H x W x D)	90 x 108 x 74
	Accessories	–

Monitoring relays for special applications



Loop monitoring relays monitor conductor loops, for example, supply leads of mobile machines and devices, for interruptions and short-circuits.

Ordering information

Supply voltage U_s		AC 16...72 V/DC 9,6...94 V, AC/DC 70...300 V
Measuring circuit	Loop resistance $R >$	■
	Rated frequency	42...460 Hz
	Hysteresis approx.	1...40 %
	Response time	in case of open loop connection ($R > 50$) ≤ 40 ms in case of closed loop connection ($R >$) ≤ 500 ms in case of extraneous voltage ($> U$) ≤ 100 ms
	Response delay	0.1...10 s
	Response value U_A	0.1...100 Ω
Alarm LEDs	Operation	■
	Alarm	■
	Loop resistance $> R$	■
	Extraneous voltage $> U_f$	■
Switches/buttons		TEST/RESET/MENU
Switching elements	Number of switching elements	2 x 1 changeover contact
	Operating principle	N/O or N/C operation
Enclosure	Enclosure dimensions in mm (H x W x D)	90 x 36 x 70.5
	Accessories	Mounting clip

Supply voltage U_s ¹⁾	Type	Art. No.	
		Screw-type terminal	Push-wire terminal
AC 16...72 V, 15...460 Hz/DC 9.6...94 V	GM420-D-1	B93082001	B73082001
AC 70...300 V, 15...460 Hz/DC 70...300 V	GM420-D-2	B93082002	B73082002

¹⁾ Absolute values

Accessories

Description	Art. No.
Mounting clip for XM420 enclosure	B98060008

Retrofit

Is your system still state of the art?

Even the most modern electrical systems cannot escape the marks of time. Whether diminishing operational reliability, changed legal stipulations or increasing energy costs: Upgrading to the respective current state of the art is indispensable. Products for monitoring energy quality and fault search are typically retrofitted.

Risk assessment according to operating safety regulations: Does your presently installed monitoring equipment recognise symmetrical and asymmetrical insulation faults?

Symmetrical and asymmetrical insulation faults present a high risk potential. Bender insulation monitoring devices continuously monitor your systems, insulation faults are captured and reported. Bender insulation monitoring devices comply with IEC 61557-8.

We will check your electrical installations and provide you with recommendations on how to proceed further.

Bender delivers flexible solutions for retrofit projects

Modern monitoring methods can be integrated in older installations as well – also during ongoing operations. Retrofitting is possible via devices such as divisible transformers, whereby the transformers are not even required to be shut down nor must cable installations be disconnected.

Successor devices from Bender can conveniently replace older installations. Long-term availability is thus guaranteed.



POWERSCOUT®

Find out today what won't happen tomorrow

Moisture, deterioration, dirt, mechanical damage or faults due to the impact of current, voltage and temperature cause malfunctions in every electrical installation. The web-based software solution POWERSCOUT® helps you detect malfunctions at an early stage and eliminate the causes in an economically reasonable way. This guarantees high installation and operational safety and reduces costs.

Analysis – as individual as your system– as simple as possible

Predictive maintenance prevents downtimes, reduces costs and staff deployment. POWERSCOUT® informs you about the condition of your electrical installation at all times, since the meaningful visualisations with flexible dashboards can be retrieved via any display device: smartphone, laptop, computer. On request, POWERSCOUT® sends you graphically processed reports at specified intervals.

Continuous monitoring instead of random tests

Manual data acquisition is time consuming, error prone and only provides random sampling results. POWERSCOUT® gives you an insight into the entire data of your installation at any time, since all measured values are automatically and continuously saved. Your data is stored reliably and remains available for years.

Basis for periodic verification

The automated POWERSCOUT® report on residual currents forms the basis for measuring without switch-off by means of periodic verification. In order to maintain the correct status for electrical installations and stationary electrical equipment, periodic verification must be carried out.

This can be ensured, for example, by means of continuous monitoring of the installation carried out by qualified personnel. In this case, it would be smart to rely on continuous monitoring with multi-channel residual current monitoring systems (RCMS) and an evaluation (CP700) adapted to the system. The automatic POWERSCOUT® reports based on this monitoring enable the qualified person in charge to adjust the time limits for the insulation test within the context of periodic verification.

Analysis

- Continuously recording insulation values
- Recognising connections and optimising maintenance
- Cross-system evaluation possibilities
- Access from any place
- Supporting investment decisions

Predictive maintenance

- Higher availability
- Continuous monitoring
- Early detection of gradually developing insulation faults
- Early detection and reporting of short-time insulation degradation
- Less costs incurred due to unexpected malfunctions and shut-downs

Reports

- Historical comparisons
- Safe storage of measured values
- Event and alarm statistics

Web-based software solution
POWERSCOUT®



Support during all stages

Comprehensive service for your installation: remote, by phone, on site

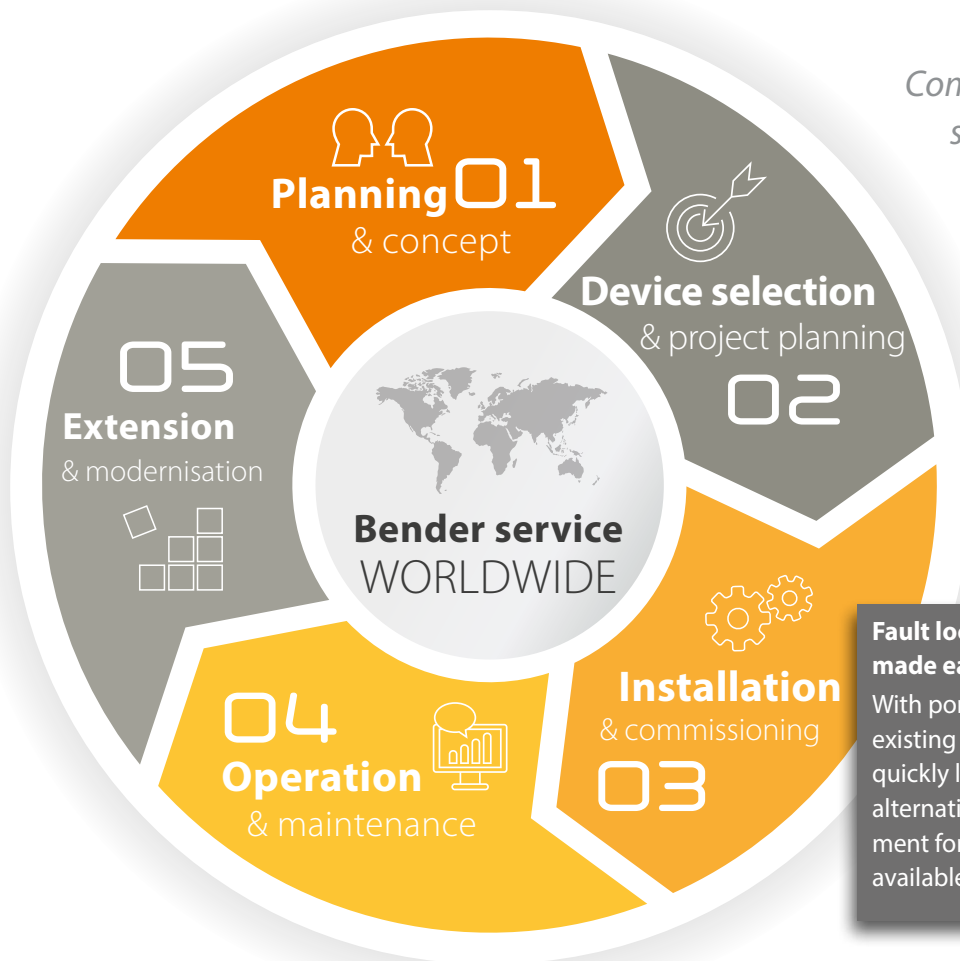

Competent service for maximum safety and high availability of your installation



Fault location – made easy

With portable fault location systems, existing insulation faults can be quickly located. They are the best alternative if no stationary equipment for insulation fault location is available.

From planning to modernisation – Our extensive know-how is at your disposal during all project phases.

Furthermore, with our first-class service we guarantee maximum safety for your electrical installations.

We offer services ranging from support over telephone to repairs and on-site service – with modern measuring devices and competent employees.

Secure yourself:

- High availability of your installation thanks to fast reaction to fault messages
- Increased profitability of your capital expenditure (CapEx) via optimised maintenance processes
- Targeted operating expenditure (OpEx) due to less downtimes and shorter service visits
- Support for your prospective system monitoring and regular tests of your system/power quality/monitoring devices
- Automatic control, analysis, correction, new settings/updates
- Competent assistance with setting changes and updates

Bender Remote Assist

Bender Remote Assist offers you support via remote access, high-quality service and advice for your challenging task consisting in ensuring consistent high safety in your systems.

Many service visits, fault clearance but also analyses and controls can be carried out remotely – without the expenses of time and money that an on-site visit of a technician implies.

This fast, efficient help and advice by our expert network allows the highest possible availability of your system.

Bender. So that your world is safer.

Our world is networked on a global scale; it is digital, mobile and highly automated – whether in manufacturing industry, inside or outside buildings, in operating theatres and power stations, in trains, underwater or underground: it never stands still and it is more dependent than ever on a reliable and, above all, safe electrical power supply.

And exactly that is our mission: we make electricity safe. Using our technologies we ensure that electricity is permanently available and guarantee faultless protection against the hazards of electric shock. We protect buildings, plants and machinery and therefore your investments and plans. But what we primarily protect are the lives of the people who are involved with electricity.

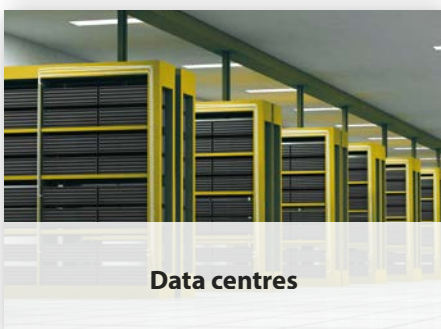
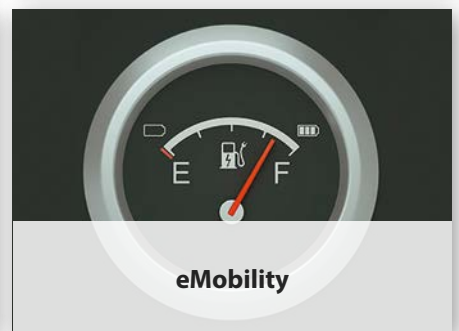
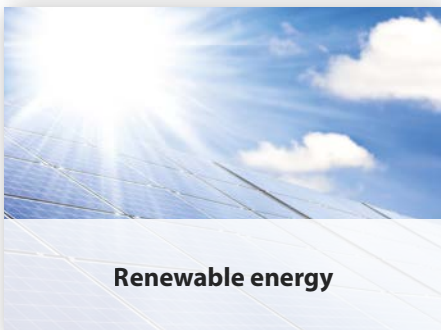

www.bender.de



Bender GmbH & Co. KG

P.O. Box 1161 • 35301 Grünberg • Germany

Londorfer Straße 65 • 35305 Grünberg • Germany

Tel.: +49 6401 807-0 • Fax: +49 6401 807-259

E-mail: info@bender.de • www.bender.de

Photos: iStock (© Eimantas Buzas, © Petair), Adobe Stock (© Paolo Sartorio, © Gabriele Rohde, © Rainer Fuhrmann), Fotolia (© Ramona Heim, © elgris, © tomas), 123RF (© Gerard Koudenburg, © Volker Rauch, © stefan 77), Thinkstock (© monkeybusinessimages), Bender archives.



BENDER Group