

ELECTRICAL SAFETY  
POWER QUALITY  
ENERGY MANAGEMENT



## Graphene Power Quality Meter - GPQM96

### Power Quality Meter

- Power Quality Measurement with colorful LCD interface
- Comply with IEC62053 class 0.2S
- Measurement sampling rate of 8kHz
- Event waveform recording (8MB memory)
- Harmonics Measurement 2-63<sup>rd</sup> Harmonic, incl THD and TDD

# Graphene Power Quality Meter - GPQM96

## Power Quality Meter



### Product Description

The GPQM96 is part of the new smart Graphene-Meter-Series and a digital universal measuring device to measure and display electricity network values and conditions. With its standardized dimensions of 96 x 96 mm, the device is intended for front panel mounting.

The range of measurements extends from voltages and currents to power and energy meters to measured quantities of the voltage quality, such as THD and the individual harmonics up to the 63rd order. The accuracy of active energy measurements corresponds to class 0.2S in accordance with DIN EN 62053-22.

The GPQM96 is suitable for 2-, 3- and 4-wire systems and, in its respective version, for TN, TT, and IT systems. This allows monitoring single and polyphase systems. Various communication interfaces like Modbus RTU, Modbus TCP/IP, Bacnet, DIs/DOs ensure smooth communication with any other system.

### Device Features

- Accuracy class according to IEC 62053-22: 0.2S
- High Resolution Failure Record with 8kHz
- Colorful LCD interface
- Harmonics 2~63<sup>rd</sup> Harmonic, THD, TDD
- Support voltage sag, swell and SOE events recording
- Full Real-time Data Measurement
- 3 current and 3 voltage inputs
- 8MB internal memory
- 2digital input / 2 relay output (optional module for additional DI/DO/AI/AO)
- Modbus RTU
- Modbus TCP / Bacnet

### Typical Applications

- Continuous monitoring of the power quality
- Collection of relevant data for energy management systems
- High-resolution waveform recording allows analysis of power quality phenomena

### Certifications & Compliances



# Technical Specification

## Power Supply

Rated Voltage	AC/DC 80~270V
Power Consumption	≤10VA
Withstand voltage	≥2kV

## Communication / Interface

### RS-485: Modbus-RTU (Default)

Physical interface	RS-485 / Optional module Modbus TCP
Communication speed	Up to 115.2 kbps
Communication protocol	Modbus-RTU / Modbus-TCP IP

## Relay output

Capacity	5A/250 VAC; 5A/30 VDC
Isolation voltage	Isolation 2000 VAC

## Energy pulse output

Pulse width	80ms±20%
-------------	----------

## Digital input

Sensitivity	AC220 Input
Isolation voltage	2000 VAC

## Measuring circuit

### Measuring voltage inputs

Rated range	400 VAC L-N (690 VAC L-L)
Resolution	0.1 V
Impedance	> 1 MΩ
Over load	1.2VIn continuous / Instantaneous : 2 times/10s
Safety Requirement	As per IEC61010-1 CAT III
Frequency	45-65 Hz

### Measuring current inputs

Rated range	5A/1A, (continuous: 1.2In)
Resolution	1 mA
Impedance	≤20mΩ/per phase
Power consumption	≤0.1 VA/per phase
Over current	Instantaneous : 10 times/5s

## Working Environment

Working temperature	-10°C to 60°C
Storage temperature	25°C to 70°C
Relative humidity	5 ~ 95% RH, no condensation
Protection degree	Front case IP65, rear case IP20

## Other

Electrostatic discharge immunity	IEC 61000-4-2-III
Radiated, radio-frequency, electromagnetic field immunity	IEC 61000-4-3-III
Electrical fast transient/burst immunity	IEC 61000-4-4-IV
Surge immunity	IEC 61000-4-5-IV
Immunity to conducted disturbances, induced by radio-frequency fields	IEC 61000-4-6-III
Power frequency magnetic field immunity	IEC 61000-4-8-III
Voltage dips, short interruptions and voltage variations immunity	IEC 61000-4-11-III

## Measurement Parameters

### Power Quality Analysis

Wave Sampling	8kHz
Harmonic	2~63rd Harmonic, THD, TDD
Voltage Sag/Swell	Waveform record
Unbalance	Voltage-, current- and zero sequence
Voltage/Freq. Deviation	Setpoint alarm and record
Rapid Voltage Alteration	Trigger DO point, waveform record
Real-time Data	Voltage, Current, Active power, Reactive power, Apparent Power, Power Factor, Frequency

Measurement Channel	4 channels for each: Voltage / Current
Real-time Data	Voltage, Current, Active power, Reactive power, Apparent Power, Power Factor, Frequency

## Energy

Energy	Positive / Negative active, reactive, apparent energy; Positive / Negative base wave active, reactive energy
History Energy	Storage to build in memory
Multi-tariff energy	2 tariff, 6 time period, 2 time zone

## Demand

Real-time Demand	fixed- and slide window record value
------------------	--------------------------------------

## Data and Event Record

Memory	8MB
Max. / Min Record	min/max voltage L-N, voltage L-L, current, frequency, power, energy
SOE Record	Yes
PQ Record	Yes

## Accuracy

Voltage/ Current	±0.2%
Re-, Active/Apparent power	±0.2%
Active Energy	IEC 62053-22 Class 0.2S, IEC 61557-12 Class 0.2
Reactive Energy	IEC62053-23 Class 2, IEC 61557-12 Class 2
Power Factor	0.20%
Frequency	±0.01Hz

# Dimensions & Ordering Code

## Ordering Code for GPQM96

GPQM96		Fixed Eetarp Product Code - Base Unit
X		Reserved
X		Reserved
X		Reserved
X		Reserved
C		Modbus RS485
X	Module 1	(FM2) 1 = 4 digital inputs (FM3) 2 = 2 relay outputs (FM4) 3 = 2 analog inputs : mA (FM6) 4 = 2 analog outputs: mA
X	Module 2	(FM7) 5 = Com module - RJ45, Modbus/TCP (FM8) 6 = Com module - DB9, Profibus - DP (FM11) 7 = Com module - additional RS485, Modbus-RTU
X	Module 3	(FM13) 8 = Com module - BACnet/MSTP communication (FM14) 9 = Com module - BACnet/IP communication (FM18) A = Com module - 2 x RJ45 Ports with webserver (FM22) B = Com module - Profinet
X	Module 4	x = No extended module  <b>Remark:</b> Max 4 extended module Only 1 additional Com module can be add-on

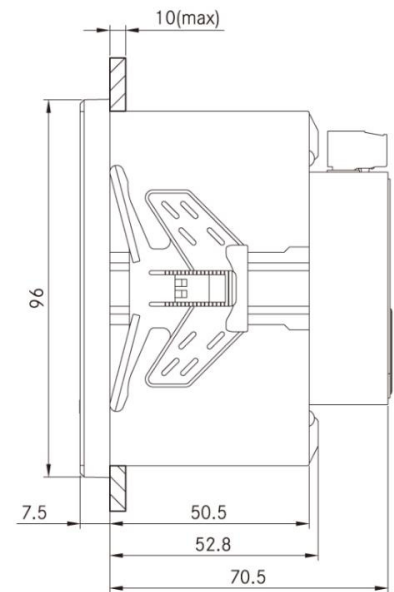

## Common GPQM96 Variants

Order Number	Type	Features
GPQM96XXXXCXXXX	GPQM96	GPQM96 + 8MB memory + 2xDI, 2xDO (Basic model)
GPQM96XXXXC5XXX	GPQM96	Basic model + Modbus TCP/IP
GPQM96XXXXC51XX	GPQM96	Basic model + Modbus TCP/IP + 4 DI

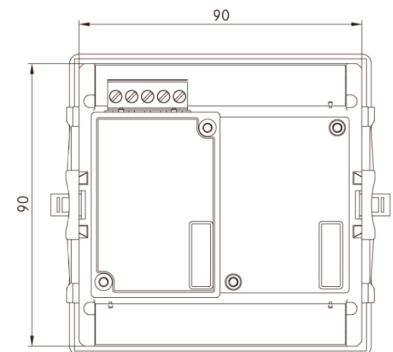

### Eetarp Engineering Pte Ltd

11 Woodlands Close, #08-13 | Woodlands 11  
Singapore 737853  
Tel: +65 6339 3651 | Fax: +65 6339 3667  
Email: [contact@eetarp.com](mailto:contact@eetarp.com)  
CRN: 200001617K

### Eetarp Power (M) Sdn Bhd

A-5-11, Blk Allamanda  
10 Boulevard, Lebuhraya Sprint  
PJU 6A 47400, PJ | Selangor, Malaysia  
Tel: +603 7729 3973 | Fax: +603 7729 8973  
E-Mail: [contact@eetarp.com](mailto:contact@eetarp.com)  
CRN: 1205228P

### Partners

Australia | China | India | Indonesia | Japan | Philippines | South Korea | Taiwan | Thailand | Vietnam

[www.eetarp.com](http://www.eetarp.com)